

Step 1
-Ensure back ass'y is perpendicular to base (tack only)

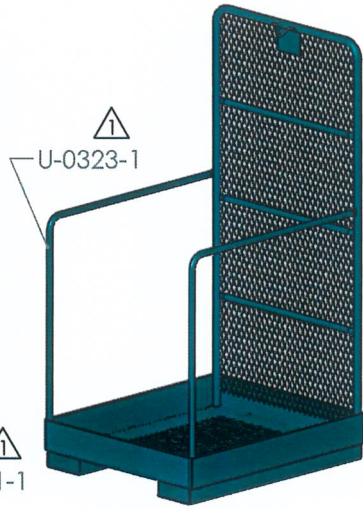

Step 2
-Ensure side frames are parallel (tack only)

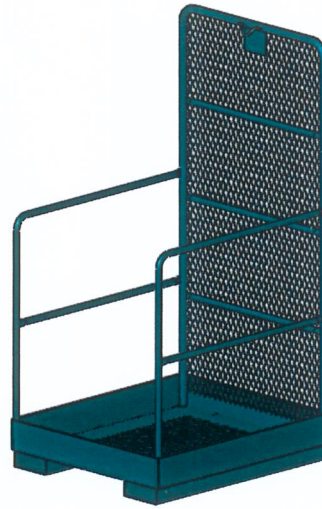

Step 3
- Add side Xpcs (tack only)

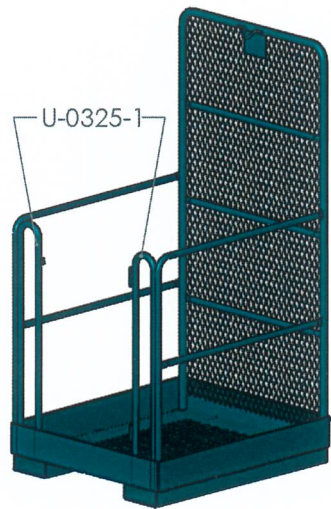
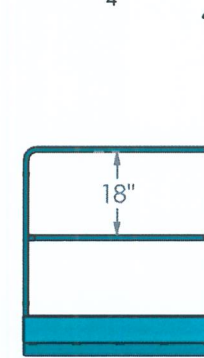

Step 4
- Add Side Frame Supports (tack only)

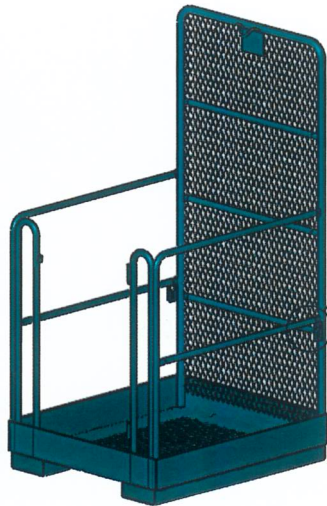

Step 5
- Weld complete
- Add Chain Hooks

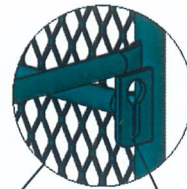

U-0322-2
or
U-1298 (AS198)

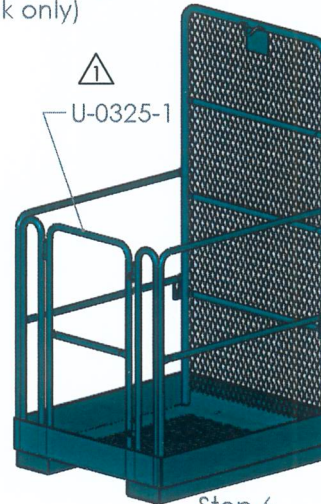

Step 6
- Insert gate
- Ensure proper functionality

REVISIONS			DATE	APPROVED
ZONE	REV.	DESCRIPTION		
	1	drawing numbers updated/added	5/13/16	VP
	2	drawing number updated	6/25/18	VP
	3	drawing and part number added	2/20/19	VP
	4	notation added	9/16/22	DM



PERMIT TO PRACTICE # 1001337

Meets

ANSI/ITSDF B56.1-2020 Standards

- Capacity 500 Lbs.
- Yield Strength 250 MPa / 36 KSI
- Safety Factor 3:1

DIMENSIONS ARE IN INCHES
TOLERANCES:
FRACTIONAL $\pm 1/32"$
ANGULAR: MACH $\pm .5$ BEND $\pm .5$
TWO PLACE DECIMAL $\pm .010$
THREE PLACE DECIMAL $\pm .005$
UNLESS OTHERWISE STATED

	NAME	DATE
DRAWN	Dean S.	9/23/5
CHECKED	VP	5/13/16
ENG APPR.		
MFG APPR.	VP	5/13/16

Unitran Manufacturers

510
Assembly

PROPRIETARY AND CONFIDENTIAL
THE INFORMATION CONTAINED IN THIS DRAWING IS THE SOLE PROPERTY OF Unitran Manufacturers Ltd. ANY REPRODUCTION IN PART OR AS A WHOLE WITHOUT THE WRITTEN PERMISSION OF Unitran Manufacturers Ltd. IS PROHIBITED.

DO NOT SCALE DRAWING

PART NO.	DWG. NO.	REV.
890/510	U-0328	4
SCALE:	WEIGHT:	SHEET 1 OF 1